

Technical Data

Max Boring Capacity	35 mm
Max Speed With Angular Bearings	3500 RPM
Max Speed With Tapered Bearing	1500 RPM
Spindle Concentricity	0.005 mm
Belt Type	Timing Belt
Pully Type	8M
Spindle Nose	ISO 40
Motor Rating At 50 HZ	2.2 ~ 3 kw
Bearing Arrangement	(5×7212 b) or
Bearing Arrangement	(2×32212) + (2×7212 b)
Weight	130 kg
Color	

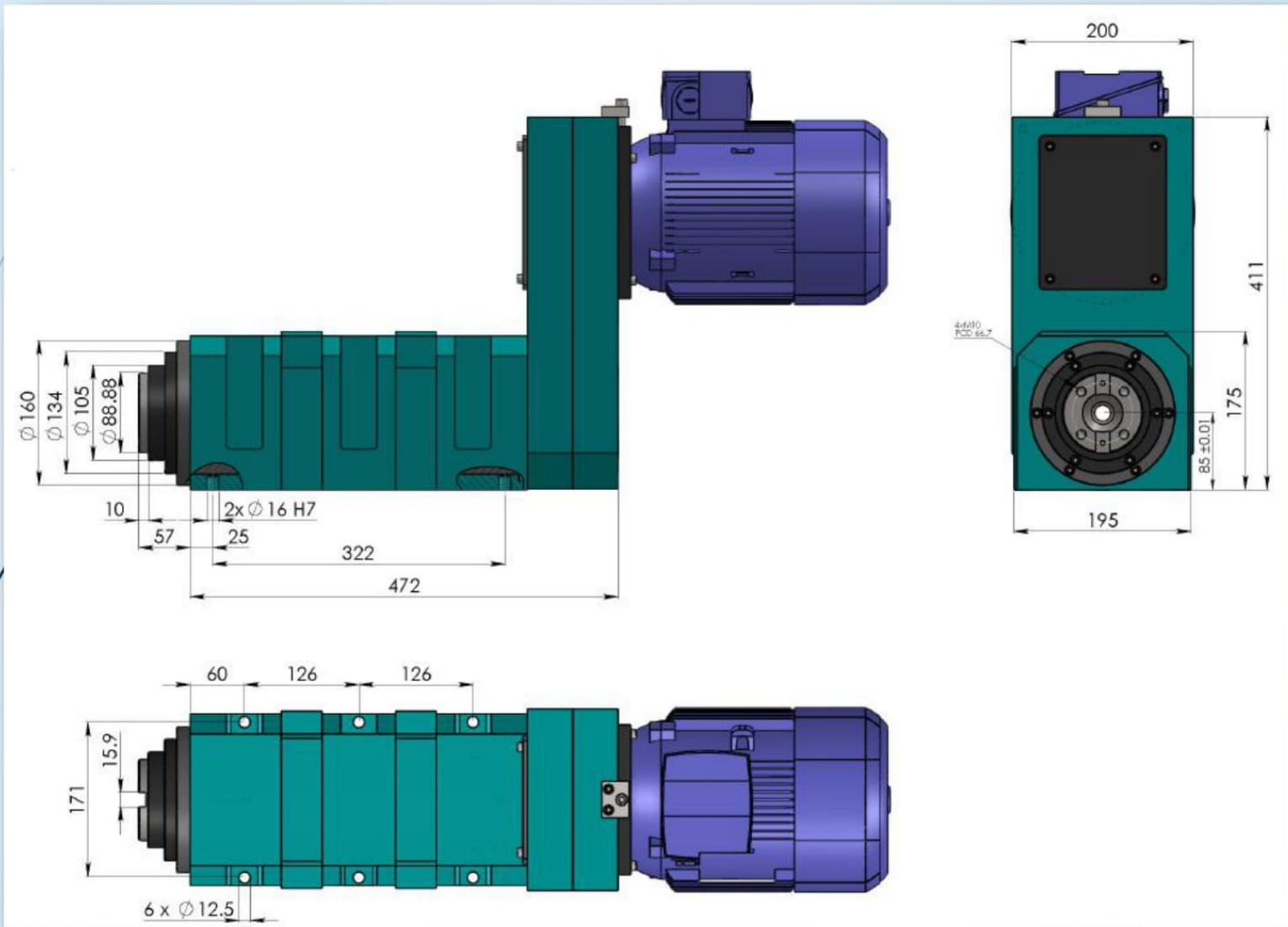





Application Guide For Milling Boring Spindle Unit. Iso 40

