**FSP-S.D&T.S.U.20-F****Order Code: #104**

Technical Data

Total Stroke	100 mm
Adjustable Stroke	0 ... 100 mm
Tapping Capacity	M 20
Spindle Nose	Iso 30
Servo Motor Spindle	1.5 kw/ 2000 RPM
Servo Motor Feed	0.7 kw/ 3000 RPM
Timing Belt Type	5M
Ball Screw Supports	HIWIN
Ball Screw And Nut	HIWIN – 16 - 05
Bearing Arrangement	(2×32006) + (1×6008) + (1×6208) or(2×6006) + (1×6008) + (1×6208)
Weight	65 kg
Color	

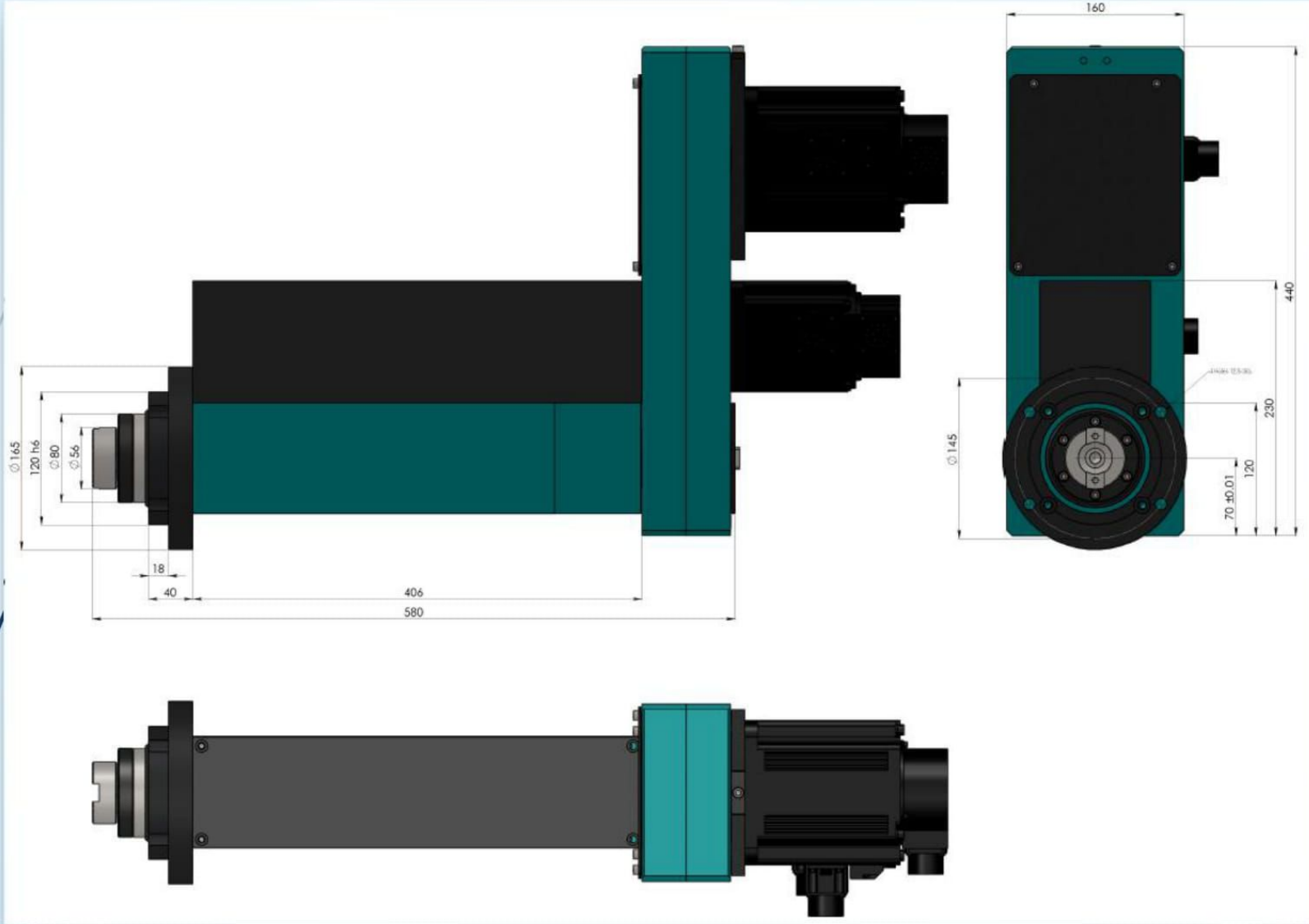





Practical Guide For Drilling & Tapping Spindle Unit

