

**Drilling Spindle Unit.12 (Without Flange)****Technical Data**

Total Stroke	80 mm
Drilling Stroke	30 mm
Pneumatic Rapid Advance	50 mm
Drilling Capacity	φ 12
Speed Rate At 50 HZ	300 – 1500 PRM
Spindle Nose	ER 25
Timing Belt Type	5M
Chrome Plated Quill, Guided In Honed Housing	0.05 clearance
Spindle Motor	0.75 kw
Feed Working Pressure	2 – 6 bar
Speed Adjustment	Hyd. Speed controller
Bearing Arrangement	(2×32004) + (2×6007) or (2×6004) + (2×6007)
Weight	50 kg
Color	

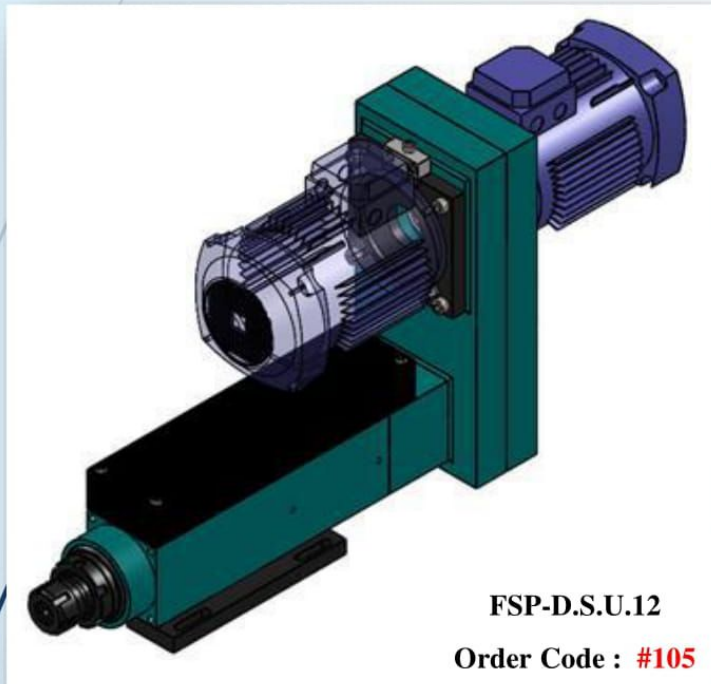

