

### Technical Data

Max Face Cutter Diameter	100 mm
Max Speed With Tapered Bearing	1500 RPM
Spindle Concentricity	0.01mm
Belt Type	Timing Belt
Pully Type	8M
Speed Rate At 50 HZ	920 – 1500 PRM
Motor Rating At 50 HZ	2.2 – 3 kw
Spindle Nose	Iso 40
Bearing Arrangement	(2×32014) + (1× NA 4913)
Weight	80 kg
Color	

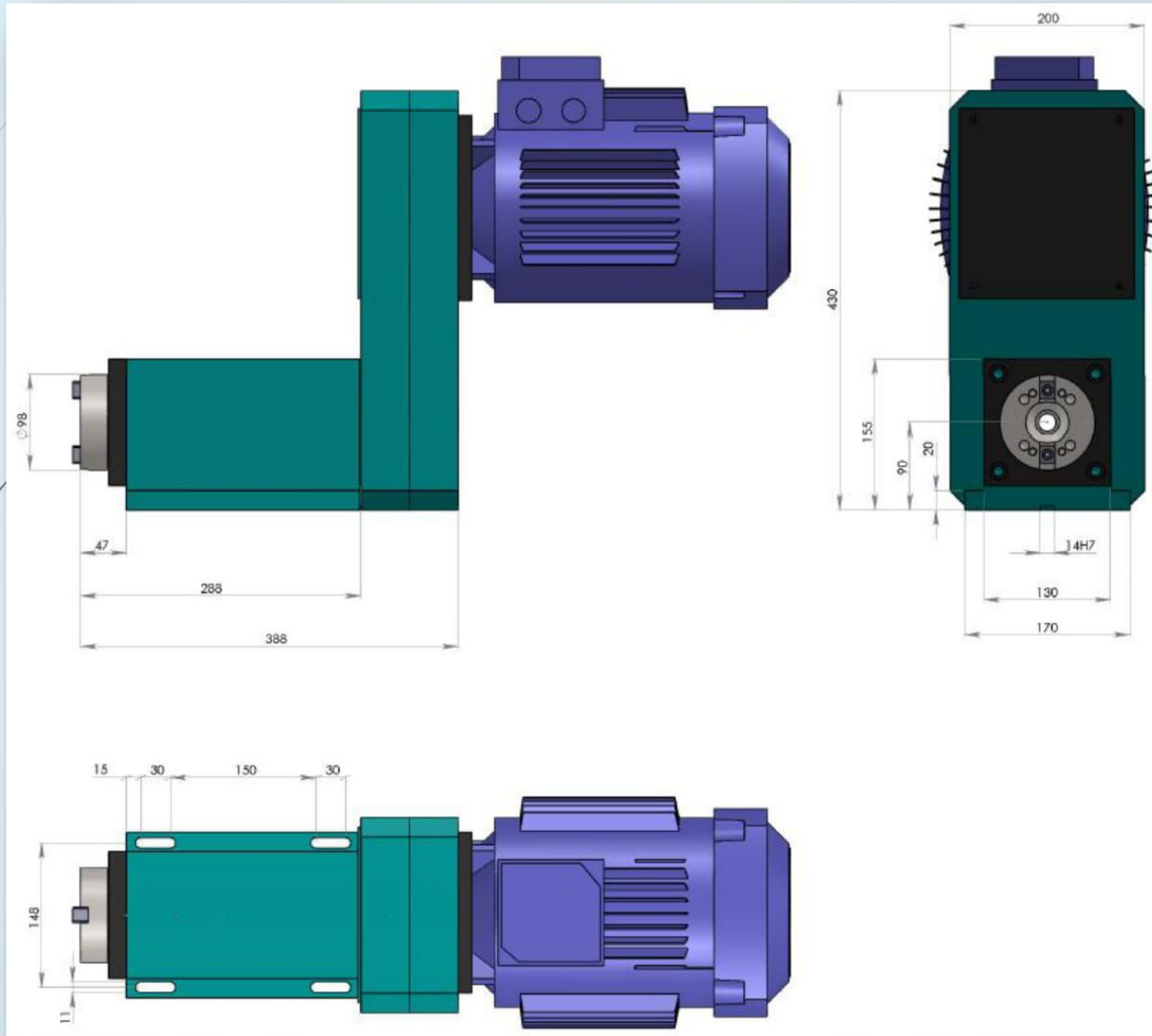





## Application guide for Milling Spindle Unit. Iso 40

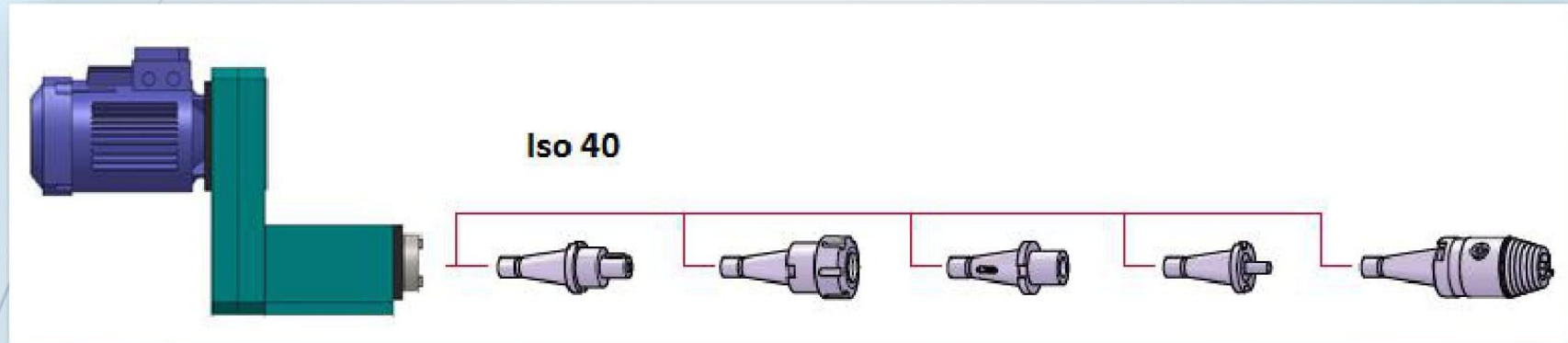

### Important Features

Option: Coolant Through Adapter and Drawbar

2 Aluminum Covers. Rotation  $4 \times 90$  Degree

Tool Retention With Drawbar

Automatic Tool Changing Unit

Front And Rear Motor Arrangement

