

**CNC Drilling Spindle Unit.30 (Type 2)****Technical Data**

Total Stroke	100 mm
Adjustable Stroke	0 ... 100 mm
Tapping Capacity	M 24 mm
Drilling Capacity	φ 30 mm
Spindle Nose	ISO 40
Servo Motor Spindle	2 kw/ 2000 RPM
Servo Motor Feed	1 kw/ 3000 RPM
Timing Belt Type	8M
Ball Screw Supports	HIWIN
Ball Screw And Nut	HIWIN – 25 - 05
Bearing Arrangement	(5×7011) + (1×3213 b)
Weight	160 kg
Color	

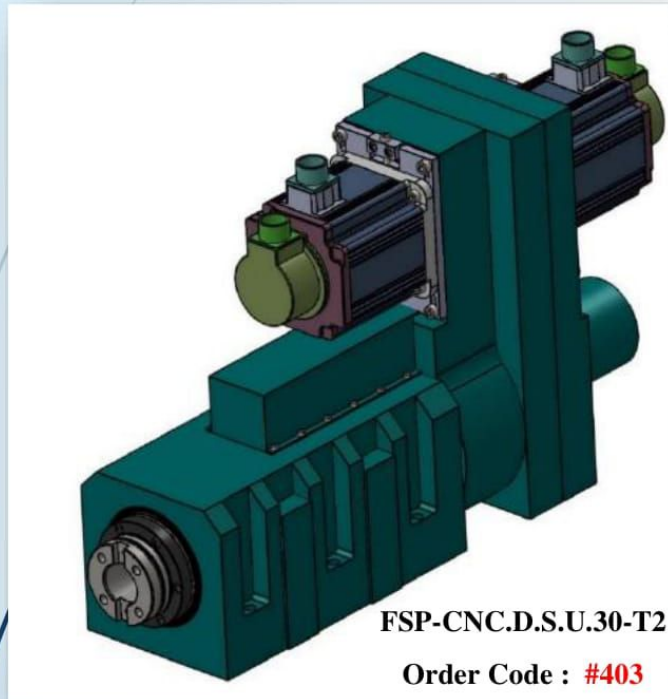

