

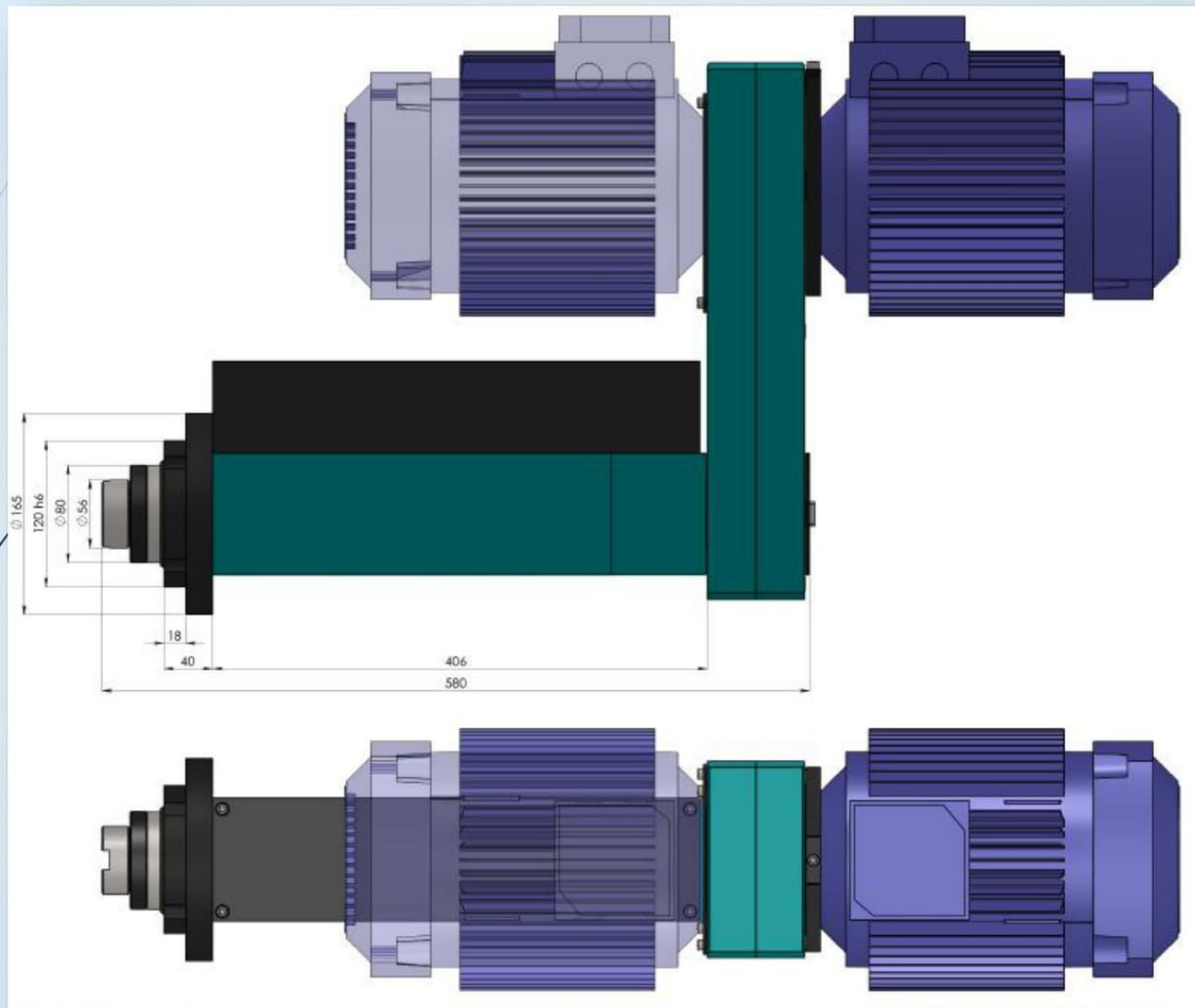

Technical Data

Total Stroke	100 mm
Adjustable Drilling Stroke	50 mm
Pneumatic Rapid Advanced Stroke	50 mm
Drilling Capacity	φ 20 mm
Speed Rate At 50 HZ	920 – 1500 PRM
Motor Rating At 50 HZ	1.5 kw / 1450 RPM
Spindle Nose	Iso 30
Timing Belt Type	5M
Chrome Plated Quill, Guided In Honed Housing	0.05 clearance
Feed Working Pressure	2 – 6 bar
Speed Adjustment	Hyd. Speed controller
Bearing Arrangement	(2×32006) + (1×6008) + (1×6208) or (2×6006) + (1×6008) + (1×6208)
Weight	65 kg
Color	







Practical Guide For Drilling Spindle Unit

