

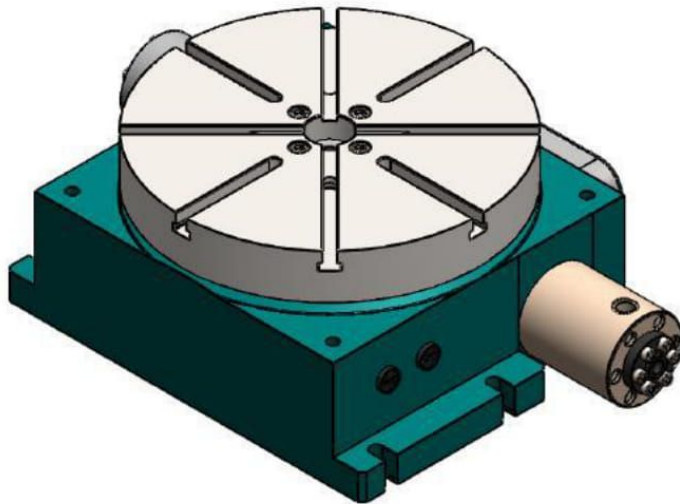

Horizontal Hydraulic Index Table. 400



FSP-H.H.I.T.400

Order Code : #804

Technical Data

Table Top Dimension	400 mm
Top Face Parallelity	0.01 mm
Weight Handline Capacity	750 kg
Max Index Angle	180 Degrees
Min Index Angle	15 Degrees
Rotation Direction	CW, CCW
Indexing Accuracy	± 6 s
Working Pressure	Max 30 bar
Weight	250 kg
Color	



