

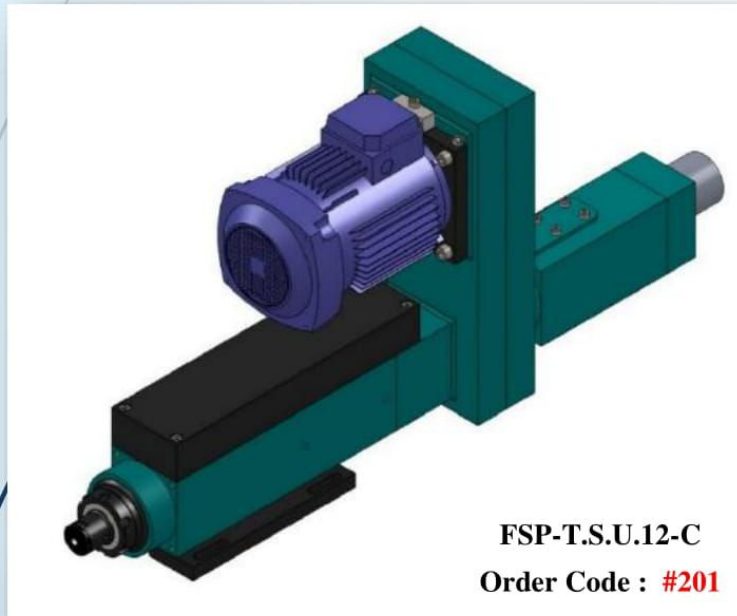

Tapping Spindle Unit.12 (with Clutch)



Technical Data

Total Stroke	80 mm
Pneumatic Rapid Advance	50 mm
Adjustable Stroke	0 ... 30 mm
Tapping Thread Pitch Capacity	MIN: 0.7 mm MAX: 2.0 mm
Speed Rate At 50 HZ	300 – 1000 PRM
Motor Rating At 50 HZ	1.1 kw / 925 RPM
Spindle Nose	Quick Change Tapping Chucks
Timing Belt Type/	5 M
Bearing Arrangement	(2×32004) + (2×6007) or (2×6004) + (2×6007)
Weight	65 kg
Color	



